



Curtin University

Biosafety Manual

Health & Safety



CONTENTS

1	Biosafety	1
1.1	Principles	1
1.2	Biosafety Advisor	1
1.3	Institutional Biosafety Committee (IBC)	2
2	Planning New Work	2
2.1	Planning Stage	2
2.2	Hazard Identification	2
2.3	Risk Assessment	3
2.4	Pre-Acquisition Tool	3
3	Sources of biosafety information	4
3.1	Australian/New Zealand Standard 2243.3:2022 Safety in laboratories Part 3: Microbiological safety and containment.	4
3.2	Biosafety Training	4
3.2.1	Working with Genetically Modified Organisms (GMOs) training course	4
3.2.2	Purchase the Department of Agriculture online quarantine training course	4
3.2.3	Non-Curtin sources of biosafety training	4
4	Genetically Modified Organisms	4
4.1	Pre-commencement Approval Required	4
4.1.1	Exempt Dealings (EDs)	5
4.1.2	Notifiable Low Risk Dealings (NLRDs)	5
4.1.3	Dealings Not involving an Intentional Release (DNIRs)	5
4.1.4	Dealings involving an Intentional Release (DIRs)	5
4.2	Legislation governing the use of GMOs in Australia - the Gene Technology Act 2000	5
4.3	Working with GMOs training course	6
5	Biosecurity	6



5.1	Biosecurity principles	6
5.2	How to import biological materials or soil/sand/rock into Curtin	6
5.3	To import from overseas	6
5.4	Western Australian biosecurity	7
5.5	Legislation governing the use of biosecurity materials in Australia - the Biosecurity Act 2015	7
5.6	Purchase the Approved Arrangements Accredited Person online training course from the Department of Agriculture.	8
6	Pathogenic Microorganisms	8
7	Clinical Samples From Humans or Animals	8
8	Guidelines for the safe storage, handling and use of clinical samples	9
9	Microorganisms that are Security Sensitive Biological Agents (SSBA) or on the Defence and Strategic Goods List (DSGL)	13
9.1	Principles about the control of bioweapons	13
9.2	List of weaponisable pathogens or toxins	13
9.3	Legislation governing the use of SSBA's in Australia - the National Health Security Act - Part 3	15
10	Australian Native Animals or Plants	15
11	Plants that are Poisonous, Toxic, or Weedy	16
12	Invertebrates that are Venomous, Toxic, or Able to Act as Vectors for Disease	16
13	Transporting biological materials	16
13.1	Guidelines for transporting biological materials by walking and carrying your samples	17
13.2	Guidelines for transporting biological materials by by vehicle, post or plane	18
14	Biological Containment Facilities	20



1 BIOSAFETY

1.1 Principles

If your research or teaching involves using:

- genetically modified organisms (GMOs),
- imported biosecurity materials,
- infectious pathogenic microorganisms, or
- clinical samples from humans or animals,

you must work in accordance with all the legislative requirements, and at a standard that ensures the safety of staff, students, the wider community, and the environment.

Please remember that some biological materials must be assumed to potentially harbour infectious agents even if they are not the target of your work e.g. HIV and hepatitis viruses in blood and blood fractions, prions in nerve tissue, Epstein–Barr virus in tissue culture cells, bacteria in soil samples, phytoplasmas in plant cuttings and sap, arboviruses in insects etc.

1.2 Biosafety Partner

Curtin's Senior Health & Safety Partner (Biosafety), Dr Bernadette Bradley, is here to help you to get all the approvals you will need before you can commence your work involving biohazards and to answer all your biosafety questions.

[Dr Bernadette Bradley](#)

Ph: 08 9266 1383

Mob: 0401 103 655

Email: HazardousMaterials@curtin.edu.au





1.3 Institutional Biosafety Committee (IBC)

Curtin's Institutional Biosafety Committee (IBC) oversees the use of all genetically modified organisms (GMOs) at Curtin. Its members are also consulted about high biorisk work and advise about biosafety processes.

An IBC is a committee described in and required by federal legislation regulating the use of GMOs in Australia. IBC Members are appointed to reflect the requirement for an organisation to be advised by people who have expertise related to working safely with biohazards.

Curtin's IBC reports to Curtin's University Health and Safety Committee (UHSC). The IBC shares information with the Faculty of Science & Engineering Health & Safety Committee and the Health Sciences Health & Safety Committee.

Current IBC Members:

- [Dr Rob Steuart](#) is the Technical Operations Manager in the Curtin Medical Research Institute (CurtinMRI) Bioscience Head Office and the Chair of the IBC.
- [Mrs Dumindi Dalugoda](#) is the Manager of the Life Sciences Research Facility.
- [Ms Kelly Locke](#) is the Biosafety Technical Coordinator for the Faculty of Science and Engineering and Facility Manager of their PC3 and Ultraclean facilities.
- [Ms Kettesse Hansen](#) is a Technical Operations Coordinator in the Faculty of Science and Engineering and Facility Manager of their Centre for Crop and Disease Management.
- [Kirsty Richardson](#), a Research Officer at Harry Perkins Institute of Medical Research is the independent member.
- [A/Prof David Groth](#), is an Associate Professor in the Curtin Medical School.
- [Dr Pao Theen See](#) is a Research Fellow in the Centre for Crop Disease Management (CCDM).
- [Dr Callum Verdonk](#) is a Research Fellow in the Centre for Crop Disease Management (CCDM).
- [Prof Mark Gibberd](#) is the Director of the Centre for Crop Disease Management (CCDM).
- [Dr Bernadette Bradley](#), the Senior Health & Safety Partner (Biosafety), is the Executive Officer and Secretary of the IBC.

2 PLANNING NEW WORK

2.1 Planning Stage

Before conducting research or teaching activities at Curtin, you must:

- identify the hazards inherent in your work,
- document your safety protocols in a written risk assessment, and
- seek any approvals you need from Curtin or Government regulatory bodies.

2.2 Hazard Identification

During the planning phase of all new research or teaching work at Curtin that involves hazardous materials, you must complete a [Research Initiation Guide \(RIG\)](#).



The RIG is a quick tick-box questionnaire that helps you to identify the kinds of hazardous materials (chemicals, radiation, biological and environmental hazards) associated with the work that you plan to do. When you submit it, you will receive an email of RIG Feedback containing information about how to handle your hazardous materials safely and legally. This information forms the start of hazardous materials training personalised to your needs. The RIG Feedback also links you to any approvals you must seek from Curtin or Government regulatory bodies before you can begin work and describes the appropriate controls for your risk assessment.

Higher Degree by Research (HDR) Students must complete a RIG as part of their Candidacy approval process. Other students must use the RIG during their planning and if directed to do so by their supervisor. The RIG for Staff must be used by new Staff when planning, and by existing Staff when changing or reviewing their work activities.

The RIG Feedback from the Biosafety Section of the RIG is the same information as is found in this Biosafety Manual.

2.3 Risk Assessment

During the planning stage of any research or teaching activities at Curtin, you must assess the risks of the hazards inherent in your work and document the controls you will put in place to manage the hazards in a written risk assessment.

Log into the Staff or Student portal and find the CHARM icon to access the risk assessment module.

For assistance with completing your risk assessment [email Health & Safety](#) and one of the Health & Safety Partners will contact you.

2.4 Pre-Acquisition Tool

Before acquiring anything and bringing it onto Curtin campuses, you must complete a [Pre-Acquisition Tool \(PAT\)](#), to identify the hazards inherent in the product and seek any approvals you need from Curtin or Government Regulatory Agencies.

Acquisition of biohazardous material includes: purchasing from a commercial or private provider, being gifted, sourcing through a collaboration, or collecting from the environment. Uses of the biohazardous material include both research and teaching activities, as well as promotional uses.

Please remember that some biological materials must be assumed to potentially harbour infectious agents even they are not the target of your work e.g. HIV and hepatitis viruses in blood and blood fractions, prions in nerve tissue, Epstein-Barr virus in tissue culture cells, phytoplasmas in plant cuttings and sap, arboviruses in insects etc.

All biohazardous materials must be transported to you following the Guidelines for transporting biological materials in Section 13.

The information about the Biological Products in the PAT is the same information as is found in this Biosafety Manual.



3 SOURCES OF BIOSAFETY INFORMATION

3.1 Australian/New Zealand Standard 2243.3:2022 Safety in laboratories Part 3: Microbiological safety and containment.

Curtin's biorisk management system has been developed based on the Australian/New Zealand Standard 2243.3:2022 Safety in laboratories Part 3: Microbiological safety and containment.

Curtin staff and students have access to the Standard through the Curtin Library online. Look in the [Library Databases](#) under 'T' for Techstreet, which you can search for '2243.3:2022' to get the Standard.

Curtin has several licences to access Techstreet but remember to log out when you have finished working, so that other users can access the database. If you can't get into the Standard, it may be because other users are using all Curtin's access licences. Wait a few minutes and try again. Your downloaded copy of the Standard will self-erase after a couple of days, and you will need to go back to Techstreet to get another copy each time you need it.

3.2 Biosafety Training

Aside from reading this Manual and reading the Australian Standard, if you want or need more biosafety training, please see below.

3.2.1 Working with Genetically Modified Organisms (GMOs) training course

If you work with Genetically Modified Organisms (GMOs), or within a research facility Certified by the Office of the Gene Technology Regulator (OGTR), then you need to complete the compulsory online [Gene Technology Awareness Training](#).

3.2.2 Purchase the Department of Agriculture online biosecurity training course

[Approved Arrangement Accredited Person](#) training is available online from the Department of Agriculture. The training is mandatory for the Responsible Persons who manage Approved Arrangement biosecurity facilities, and for holders of Import Permits. The course costs about \$100 and requires credit card payment.

3.2.3 Non-Curtin sources of biosafety training

There are various free training courses available online from non-Curtin sources, including The American Biological Safety Association the has four videos about [Animal Biosafety](#) , the World Health Organisation has [11 biosafety videos](#), and the Victorian Infectious Diseases Reference Laboratory has a video about working safely in a [Class II Biological Safety Cabinet](#) .

4 GENETICALLY MODIFIED ORGANISMS

4.1 Pre-commencement Approval Required

Prior to beginning your research or teaching work using Genetically Modified Organisms (GMOs), you must [apply to the Institutional Biosafety Committee \(IBC\)](#) and get the appropriate written approvals.

There are [four classes of GM Dealing](#) .



4.1.1 Exempt Dealings (EDs)

Exempt Dealings (EDs) pose the lowest level of risk. Curtin is therefore exempt from having to notify the OGTR that EDs are being done (like for an NLRD described below), or from seeking a Licence from the Office of the Gene Technology Regulator OGTR (like for a DNIR or DIR described below). EDs must be contained within a research or teaching facility and must not involve the release of the organism into the environment. Some immortalised cell cultures have been genetically modified, you must check if an ED is required. You can perform an ED in any suitable lab. Getting IBC approval to perform an ED should only take a few days.

4.1.2 Notifiable Low Risk Dealings (NLRDs)

Notifiable Low Risk Dealings (NLRDs) pose a low level of risk. Curtin must notify the OGTR about each NLRD that is being done. NLRDs must be contained within an OGTR-Certified research facility and must not involve the release of the organism into the environment. You can only perform NLRDs in OGTR-Certified Facilities (orange door sticker). Getting IBC Approval to perform an NLRD should take about three weeks but can take up to two months.

4.1.3 Dealings Not involving an Intentional Release (DNIRs)

Dealings Not involving an Intentional Release (DNIRs) pose a higher level of risk. This class includes all dealings that are not EDs or NLRDs, and which do not involve an intentional release of the organism into the environment. DNIRs must be Licenced to Curtin University by the Office of the Gene Technology Regulator (OGTR).

If you want to perform a DNIR you must contact your [Biosafety Partner](#), who will help you through the application process. You must first apply to the IBC for permission and gain the IBC's Approval. The IBC will then apply to the OGTR for permission and gain the OGTR's Licence to do the dealing. You cannot commence your work until you receive a Licence, and this can take up to six months, so apply early to avoid delays.

4.1.4 Dealings involving an Intentional Release (DIRs)

Dealings involving an Intentional Release (DIRs) pose a higher level of risk. This class includes all dealings involving the release of the organism into the environment, usually vaccines or field trials of plants. DIRs must be Licenced to Curtin University by the OGTR.

If you want to perform a DIR you must contact your [Biosafety Partner](#), who will help you through the application process. You must first apply to the IBC for permission and gain the IBC's Approval. The IBC will then apply to the OGTR for permission and gain the OGTR's Licence to do the dealing. You cannot commence your work until you receive a Licence, and this can take between 9 and 14 months, so apply early to avoid delays.

4.2 Legislation governing the use of GMOs in Australia - the Gene Technology Act 2000

The [Gene Technology Act 2000 and Regulations 2001](#) describe a national scheme for the regulation of Genetically Modified Organisms (GMOs) in Australia. The legislation aims to make GM techniques safe for researchers, the public and the environment. However, the safety of recombinant DNA work ultimately depends on the individuals conducting it.

The object of this Act is to protect the health and safety of people and to protect the environment, by identifying risks posed by or as a result of gene technology, and by managing those risks through regulating certain dealings with GMOs.



The purpose of the Act is to ensure that all work with GMOs within Australia is carried out in such a way that threats to human health and the environment are minimised.

The [Office of the Gene Technology Regulator \(OGTR\)](#) is the administrative body under the Act. The OGTR has awarded Curtin University status as an [Accredited Organisation](#) enabling us to perform gene technology [Dealings](#), and maintain several [OGTR-Certified](#) research facilities.

The OGTR empowers the Curtin University IBC to assess and monitor the GM Dealings done at Curtin, and therefore you must get approval from the IBC before you can do any GM Dealing at Curtin.

4.3 Working with GMOs training course

If you work with GMOs, or within a research facility Certified by the OGTR, then you need to complete the compulsory online [Gene Technology Awareness Training](#).

5 BIOSECURITY

5.1 Biosecurity principles

If you want to import biological materials or environmental samples from overseas or interstate, they will be subject to biosecurity regulation.

Biosecurity is a critical part of the Government's efforts to prevent, respond to and recover from pests and diseases that threaten the economy and environment. The Government works to ensure continued market access for Australia's agricultural products and to maintain our high standards for emergency response. Australia's biosecurity system protects our unique environment and agricultural sector and supports our reputation as a safe and reliable trading nation. This has significant economic, environmental and community benefits for all Australians.

5.2 How to import biological materials or environmental samples into Curtin

There are two levels of biosecurity that apply to Western Australia:

- [State biosecurity](#) between WA and the Eastern States of Australia
- [Federal biosecurity](#) between Australia and overseas

You might need import permits from both Federal and State biosecurity, or you might just need Federal biosecurity import permit, or you might not need any permits at all.

Follow the steps below to figure out which kinds of permit(s) you need to apply for, and please contact your [Biosafety Partner](#) for assistance.

5.3 To import from overseas

Step 1. Search the Department of Agriculture [BICON](#) database for Federal biosecurity import requirements.

Step 2. Read the import conditions for your commodity to determine if you need to apply for an Import Permit. If you don't require an Import Permit, then just follow the import conditions.



Step 3. If you do require an Import Permit, then you must register (top right) to join the existing Curtin multiple user account. The Organisation Name is “Curtin University,” and the Account Administrator’s Email is “bernadette.bradley@curtin.edu.au” .

Step 4. Once you have been confirmed as a user, you can apply for an Import Permit – you will need to pay with a credit card. Sometimes you may need to bring the materials into an Approved Arrangement facility – ask your lab manager and/or your [Biosafety Partner](#) for assistance to either get access to an Approved Arrangement facility or to get the approval for your own lab.

Step 5. Complete the [Approved Arrangements for Accredited Persons \(Classes 1 to 8\)](#) online training course from the Department of Agriculture (Section 5.6).

5.4 Western Australian biosecurity

Step 1. Search the [WA Organisms List](#) to find the legal status of the organism you want to import. If it is Listed, then you can see any control requirements required. If it is unlisted or requires a permit, then you will need to apply for an Import Permit by following the links from that webpage.

Step 2. Check the [Import Requirements](#) associated with the organism. Fulfil all the listed requirements.

Step 3. At least 24 hours before importing, use the most appropriate form to notify Quarantine WA of your intent, and include a copy of any relevant Australian or Western Australian Import Permit.

[Notice of Intent \(NOI\) to import a declared pest or prescribed potential carrier into Western Australia](#)

[Notice of Intent \(NOI\) to import goods into Western Australia](#)

[Notice of Intent \(NOI\) to import subject to import permit](#)

Note: If you want more information, phone Quarantine WA on (08) 9334 1800. Curtin’s Biosafety Partner may also be able to assist you.

5.5 Legislation governing the use of biosecurity materials in Australia - the Biosecurity Act 2015

There are several Federal and State Acts of law that cover biosecurity, and it is illegal to import any biological material without adhering to all the Guidelines and Regulations associated with those Acts.

The key legislation is the:

- [Biosecurity Act 2015](#) and [Regulations \(2016\)](#)
- [Biosecurity and Agriculture Management Act 2007](#) and [Regulations \(2013\)](#)

These Acts are administered by the:

- [Department of Agriculture, Water and the Environment](#) (Commonwealth)
- [Department of Primary Industries and Regional Development](#) (State)



5.6 Purchase the Approved Arrangements Accredited Person online training course from the Department of Agriculture

[Approved Arrangements Accredited Person](#) training is available online from the Department of Agriculture. The training is mandatory for the Responsible Persons who manage Approved Arrangements quarantine facilities, and for holders of Import Permits. The course costs approximately \$100 and requires credit card payment.

6 PATHOGENIC MICROORGANISMS

Some of our people study pathogenic or infectious microorganisms, trying to find cures for diseases of people, animals, and plants, and therefore pathogens can be found in the biocontainment facilities at Curtin.

All microorganisms in Risk Groups (RG) 2, 3 or 4 must be handled at the appropriate corresponding Physical Containment (PC) level (eg. PC2 for RG2).

For information about how to handle the samples, refer to Sections 3-5 of the Australian/New Zealand Standard 2243.3:2022. The A/NZS2243.3:2022 can be accessed by searching the [library databases](#) for the Techstreet database and then for '2243.3'.

If you can handle your microorganism at the same PC level as their RG, then you don't need approval from your Biosafety Partner. This includes handling the microorganism entirely within a Class II Biosafety Cabinet if it can be infective via the respiratory route. However, if you want to use non-Standard methods, then you must contact your [Biosafety Partner](#) to help you to assess the risk before you begin work.

Some animal pathogens are zoonotic and can infect you. Please see this document about [zoonoses](#) for more information.

It is recommended that you get the appropriate immunisations listed in [The Australian Immunisation Handbook 2018](#). There may be other vaccinations available that are relevant to the samples you are handling.

It is recommended that people who work in labs containing human pathogens get an initial medical examination followed by periodic health monitoring for exposure.

If you are planning to do this work at a non-Curtin site, you still must handle your microorganisms safely, to the standard described above.

If you need to transport your microorganisms, you must transport them following the Guidelines for Transporting Biohazards (Section 13).

For your Risk Assessment, the hazard is infection with disease. The first control is handling the sample under the appropriate Physical Containment conditions or using methods approved by the IBC. A second control may be vaccination.

7 CLINICAL SAMPLES FROM HUMANS OR ANIMALS

If you are planning to conduct research or teaching activities involving samples taken from humans or animals (*for example: blood, sputum, tissue, urine, faeces, meat, bones, feathers etc.*) then you must take the points below into consideration.



Samples taken from humans or animals may contain infectious microorganisms, and you must put controls in place to protect yourself and others.

1. You or your Supervisor must check and apply for any required approval for you from the [Human Research Ethics Committee](#) or [Animal Ethics Committee](#) before you can source samples from humans or animals.
2. All samples from humans or animals must be handled as Risk Group 2, within PC2 facility, unless they are known to contain microorganisms from RG3/4. For information about how to handle your samples, refer to AS/NZS2243.3:2022 (the Australian/New Zealand Standard 2243.3:2022 can be accessed by searching the library databases <http://databases.library.curtin.edu.au/> for the Techstreet database and then for '2243.3') and this [WorkSafe guidance](#). If possible, handle your samples inside a Class II Biosafety Cabinet. If you are able to handle your samples at PC2 then you do not need to seek IBC approval to do this work. However, if you can't comply with these two documents for any reason, or you are not sure, then you must contact the Biosafety Advisor, who will help you to seek IBC assessment and approval before you can begin work.
3. Samples from humans can infect you with diseases that those people carried. Samples from animals can infect you with zoonotic diseases that those animals carried. Please see the linked document about [zoonoses](#) for more information.
4. Curtin recommends that you get the appropriate immunisations listed in [The Australian Immunisation Handbook 2018](#). There may be other vaccinations available that are relevant to the samples you are handling.
5. Some cancer cell lines are able to colonise a person if the cells are aspirated into the lungs or get in the eyes. You must treat those cancer cell lines as infectious.
6. If you are planning to do this work at a non-Curtin site, you still must handle your samples safely, to the standard described above.
7. If you need to transport your samples, you must transport them following the Guidelines for transporting biohazards (Section 13).

For your Risk Assessment, one hazard is harm to the human or animal test subject. The control is seeking and gaining approval from the HREC or AEC. For your Risk Assessment, another hazard is infection with a pathogen originating from your sample. The first control is handling the sample under PC2 conditions or using methods approved by the IBC. A second control is vaccination.

8 GUIDELINES FOR THE SAFE STORAGE, HANDLING AND USE OF CLINICAL SAMPLES

The purpose of these guidelines is to support the [Health and Safety Policy](#) and provide guidance for the safe storage, handling and use of clinical samples.

1 SCOPE AND PRINCIPLES

1.1 The term 'clinical sample', as used in this document, is used to encompass:

- all blood, blood products and derivatives, bodily fluids, excretions, and tissues
- sourced from either human or animal donors
- donated or purchased



- 1.2. These Guidelines recognise that clinical samples can be a hazard. Samples from humans can infect people with diseases that the donors carried. Samples from animals can infect people with [zoonotic diseases](#) that those animals carried.
- 1.3. These Guidelines apply to any person at Curtin University who is in any way associated with the storage, handling, use or disposal of clinical samples. Those people will act to minimise the potential for harm arising out of working with clinical samples.
- 1.4. These Guidelines describe a management system that is consistent with industry Best Practices.
- 1.5. These Guidelines allow for flexibility in the methods used to handle clinical samples, as approved by the Curtin University Institutional Biosafety Committee (IBC).
- 1.6. These Guidelines follow the principles of assessing the infection risk of the clinical samples and mitigating that risk. Following the Hierarchy of Controls, this guideline promotes the substitution of safer forms of clinical sample where possible.
- 1.7. These Guidelines recognise that some uses of clinical samples require prior approval from Curtin's Human Research Ethics Committee or Animal Ethics Committee. Any conditions placed on an approval from these Committees override the guidance outlined below.
- 1.8. These Guidelines apply to all workers, students, and visitors, whether a person is working at a Curtin Campus and any other locations where activities are undertaken by Curtin University representatives or on behalf of the University.

2 METHODS FOR USING CLINICAL SAMPLES

The methods for using clinical samples vary depending on what kind of clinical sample is being used.

2.1 Preparation before use

- 2.1.1 Complete and submit a [Research Initiation Guide \(RIG\)](#) .
- 2.1.2 Read and follow the advice from the RIG Feedback.
- 2.1.3 Get all applicable vaccinations, as described in [The Australian Immunisation Handbook 2018](#) . For work with human tissue, blood or body fluids, it is recommended that you get vaccinated against Hepatitis B, Influenza, Measles/Mumps/Rubella MMR (if non-immune), Pertussis (dTpa - diphtheria-tetanus-acellular pertussis), Varicella (chickenpox, if non-immune). For work with animals, there may be relevant vaccinations such as against Q-fever or Rabies. For work with untreated sewerage, it is recommended that you get vaccinated against Hepatitis A and Tetanus (dT or dTpa). Also consider getting any other applicable vaccines.
- 2.1.4 Get an initial medical examination for existing infections.
- 2.1.5 When completing a risk assessment, consider substituting safer forms of clinical sample where possible (see 2.3).
- 2.1.6 Make a determination about which Risk Group (see 2.3, 2.4 or 2.5) the clinical sample falls into, and handle the clinical sample at the corresponding Physical Containment (PC) level.

2.2 Handling clinical samples in the clinical setting



- 2.2.1 Follow the [National Code of Practice for the Control of Work-related Exposure to Hepatitis and HIV \(Blood-borne\) Viruses \[NOHSC:2010\(2003\)\]](#) .
- 2.2.2 If you are working off a Curtin campus (e.g. practicum placement) then your Fieldwork Risk Assessment must acknowledge that the clinical sample handling procedures of that workplace meet the standard required in 2.2.1.
- 2.3 Risk Group 1 - Use of pre-screened ex-Red Cross Blood Service products. Use of autoclaved, pasteurised, irradiated or 'fixed' clinical samples. Use of tissue from healthy, uninfected, animal-facility-sourced animals that is kept refrigerated or dried.
 - 2.3.1 Wear fully enclosed shoes that cover all parts of the foot up to the ankle, a labcoat that covers your clothing, and safety glasses. Have all hair tied back securely such that it does not touch your face below the eyebrows and does not move from its ties when the head is shaken. Wear gloves as required by risk assessment.
 - 2.3.2 After handling the clinical samples, decontaminate all surfaces, equipment, and hands using a chemical disinfectant as described in Appendix F of the A/NZS2243.3:2022. Remove lab coat and launder. Remove gloves and dispose of by autoclaving or incineration.
- 2.4 Risk Group 2 – Use of clinical samples from donors who disease status is unknown. Use of clinical samples from donors suspected/known to be infected with a RG2 pathogen.
 - 2.4.1 Wear fully enclosed shoes that cover all parts of the foot up to the ankle, a labcoat that covers your clothing, gloves, and safety glasses. Have all hair tied back securely such that it does not touch your face below the eyebrows and does not move from its ties when the head is shaken. Wear any other Personal Protective Equipment as required by risk assessment (e.g. plastic aprons or coveralls, hair covers, shoe covers, full face shields)
 - 2.4.2 Handle the clinical samples inside a Class II Biosafety Cabinet (BSCII). Centrifuge clinical samples using aerosol-tight sealed buckets or rotors. Unload the buckets in the BSCII.
 - 2.4.3 After handling the clinical samples, decontaminate all surfaces, equipment, and hands using a chemical disinfectant as described in Appendix F of the A/NZS2243.3:2022. Remove lab coat and autoclave before laundering. Remove gloves and dispose of by autoclaving or incineration.
 - 2.4.4 Get periodic health monitoring medical examinations for exposure.
 - 2.4.5 If you can't handle the clinical samples at the PC2 level, contact Curtin's Biosafety Advisor, who will help you to seek approval for your project from the IBC.
- 2.5 Risk Group 3/4 – Use of clinical samples from donors suspected/known to be infected with a RG3/4 pathogen.
 - 2.5.1 Contact Curtin's Biosafety Advisor, who will help you to seek approval for your project from the IBC.
- 2.6 Storage of clinical samples
 - 2.6.1 clinical samples must be stored in a container that will not shatter, spill or leak if dropped.
 - 2.6.2 Clinical samples should be stored as cold as practicable to inhibit microbial growth.
 - 2.6.3 Storage locations should be signposted with the biohazard symbol.



2.7 Transporting clinical samples on foot, by car, by post or by plane.

- 2.7.1 If you need to transport clinical samples, you will need to transport it following the A/NZS2243.3:2022, the Australian Code for the Transport of Dangerous Goods by Road and Rail 7th Edition (ADG7), and the International Air Transportation Association (IATA) Dangerous Goods Regulations (DGR) Category 6.
- 2.7.2 Before you physically carry samples from one lab to another, you must double contain them (e.g. in a tube inside a lidded plastic lunchbox) and label them with a biohazard symbol, a brief description of the contents, and the contact information of someone who isn't carrying the box (you can use the Biosafety Advisor if you want). Your package must survive being dropped - test an empty version of your transport system by dropping it.
- 2.7.3 To transport the samples by car, you need to fulfil the requirements of 2.7.2, plus you need to make sure that the double container (3.6.2) would survive a car crash. You can test an empty version of your transport system by (safely) throwing it hard against a wall.
- 2.7.4 To transport samples by car, post or by aeroplane, you need to make sure that the double-container (3.6.2) would survive a car crash. You can test an empty version of your transport system by (safely) throwing it hard against a wall. You also need to add enough absorbent material around your inner container (3.6.2) to soak up a spill of the whole contents and add the legally required labelling to the outer package. There is a picture in the A/NZS2243.3:2022, and your courier company or Australia Post will be able to help you to do this. If your samples are dangerous or valuable, use World Courier. Before you post any samples, make sure that the person you are sending them to has agreed to have you send them and has fulfilled any requirements for import permits that they need to fulfil.

2.8 Quarantined clinical samples

- 2.8.1 If your clinical samples have been imported from overseas or the Eastern States of Australia, then you will also need to follow the requirements of your Import Permit or AGWA Approval.

2.9 Disposal of clinical samples

- 2.9.1 Clinical samples and materials contaminated with clinical samples will be disposed of by autoclaving, incineration, or deep burial. Domestic waste disposal systems are not suitable for disposing of clinical samples.

2.10 After accidental exposure to clinical samples

- 2.10.1 The different Risk Groups of clinical samples, and the different methods of exposure to the clinical samples, result in a spectrum of risk from exposure to clinical samples. For example, spilling autoclaved clinical samples on your arm poses very little risk, whereas accidentally injecting yourself with clinical samples from a source suspected to contain a RG2 pathogen poses very high risk.
- 2.10.2 Follow the Curtin [Sharps Injury & Blood Exposure Guidelines](#) .
- 2.10.3 If possible, take a sample of the clinical samples with you to the GP, so it can be tested for disease.
- 2.10.4 [Report the incident](#) through the Health and Safety incident reporting system.
- 2.11 Requests to deviate from the Guidelines



Deviation from these Guidelines may be permitted where a risk assessment has confirmed that the deviation is as safe as the Guidelines. All deviations need to be approved by the Institutional Biosafety Committee via the Biosafety Advisor.

3 RELATED DOCUMENTS/LINKS/FORMS

- Curtin [Research Initiation Guide \(RIG\)](#).
- The Australian/New Zealand Standard 2243.3:2022 Safety in laboratories - Part 3: Microbiological safety and containment. This Standard can be accessed by searching the library databases <http://databases.library.curtin.edu.au/> for the Techstreet database and then for '2243.3'.
- National Code of Practice for the Control of Work-related Exposure to Hepatitis and HIV (Blood-borne) Viruses [NOHSC:2010(2003)] https://www.safeworkaustralia.gov.au/system/files/documents/1702/nationalcodeofpractice_control_workrelatedexposure_hepatitis_hivviruses_nohsc2010-2003_pdf.pdf .
- The Australian Immunisation Handbook 2018 <https://immunisationhandbook.health.gov.au/>
- Zoonosis awareness <https://www.commerce.wa.gov.au/worksafe/zoonoses> .
- Transporting Biological Materials (Section 13).
- Sharps Injury & Blood Exposure Guidelines https://www.curtin.edu.au/healthandsafety/wp-content/uploads/Sharps_Injuries_Guideline.pdf .

9 MICROORGANISMS THAT ARE SECURITY SENSITIVE BIOLOGICAL AGENTS (SSBA) OR ON THE DEFENCE AND STRATEGIC GOODS LIST (DSGL)

9.1 Principles about the control of bioweapons

Security Sensitive Biological Agents (SSBA) are weaponisable pathogens or toxins that could be used to make a bioweapon. The Security Sensitive Biological Agents (SSBA) Regulatory Scheme limits the opportunities for acts of bioterrorism or biocrime to occur using harmful biological agents. Curtin is not registered to work with SSBAs, and it is, therefore illegal for any of our people to store or work with SSBAs.

The Defence and Strategic Goods List (DSGL) includes a list of microorganisms that are illegal to transport internationally (under the Customs Act), and illegal to communicate (including publish) new information about (under the Defence Trade Controls Act), without the correct permits from Government Departments.

If you are planning to conduct research involving any of the following toxins, or pathogenic microorganisms, or nucleic acid sequences encoding the toxins or associated with the pathogenicity of the organisms, then you must contact your [Biosafety Partner](#) immediately, to begin the process of seeking the required approvals.

9.2 List of weaponisable pathogens or toxins

Toxins:

Abrin, Aflatoxins, Botulinum toxins, Cholera toxin, *Clostridium perfringens* alpha/beta 1/beta 2/epsilon/iota toxins, Conotoxin, Diacetoxyscirpenol toxin, HT-2 toxin, Microcystin (Cyanoginosin), Modeccin, Ricin, Saxitoxin, Shiga toxin, *Staphylococcus aureus* enterotoxins or hemolysin alpha toxin or toxic shock syndrome toxin (formerly known as *Staphylococcus* enterotoxin F), T-2 toxin, Tetrodotoxin, Verotoxin and shiga-like ribosome inactivating proteins, Viscum Album Lectin 1 (Viscumin), Volkensin.



Human pathogenic viruses:

Andes virus, Chapare virus, Chikungunya virus, Choclo virus, Congo-Crimean haemorrhagic fever virus, Dobrava-Belgrade virus, Eastern equine encephalitis virus, Ebolavirus (all members of the Ebolavirus genus), Guanarito virus, Hantaan virus, Hendra virus (Equine morbillivirus), highly pathogenic influenza virus infecting humans, reconstructed 1918 influenza virus, Japanese encephalitis virus, Junin virus, Kyasanur Forest disease virus, Laguna Negra virus, Lassa fever virus, Louping ill virus, Lujo virus, Lymphocytic choriomeningitis virus, Machupo virus, Marburgvirus (all members of the Marburgvirus genus), Middle East respiratory syndrome-related coronavirus (MERS-CoV), Monkeypox virus, Murray Valley encephalitis virus, Nipah virus, Omsk hemorrhagic fever virus, Oropouche virus, Powassan virus, Rift Valley fever virus, Rocio virus, Sabia virus, Seoul virus, Severe acute respiratory syndrome-related coronavirus (SARS-related coronavirus), Sin Nombre virus, St Louis encephalitis virus, Suid herpesvirus 1 (Pseudorabies virus; Aujeszky's disease), Tick-borne encephalitis virus (Far Eastern subtype), Variola virus, Venezuelan equine encephalitis virus, Western equine encephalitis virus, Yellow fever virus.

Human pathogenic bacteria:

Bacillus anthracis, *Brucella abortus*, *Brucella melitensis*, *Brucella suis*, *Burkholderia mallei* (*Pseudomonas mallei*), *Burkholderia pseudomallei* (*Pseudomonas pseudomallei*), *Chlamydia psittaci* (formerly known as *Chlamydia psittaci*), *Clostridium botulinum*, *Clostridium argentinense* (formerly known as *Clostridium botulinum* Type G) botulinum neurotoxin producing strains, *Clostridium baratii* botulinum neurotoxin producing strains, *Clostridium butyricum* botulinum neurotoxin producing strains, *Clostridium perfringens* epsilon toxin producing types 2, *Coxiella burnetii*, Shiga toxin producing *Escherichia coli* (STEC, enterohaemorrhagic *E. coli* EHEC or verocytotoxin producing *E. coli* VTEC) of serogroups O26/O45/O103/O104/O111/O121/O145/O157 and other shiga toxin producing serogroups, *Francisella tularensis*, *Rickettsia prowazekii*, *Salmonella typhi*, *Shigella dysenteriae*, *Vibrio cholera*, *Yersinia pestis*.

Human pathogenic fungi:

Coccidioides immitis, *Coccidioides posadasii*.

Animal pathogenic viruses:

African horse sickness virus, African swine fever virus, Avian influenza virus which are uncharacterised or having high pathogenicity, Bluetongue virus, Foot-and-mouth disease virus, Goatpox virus, Herpes virus (Aujeszky's disease), Lumpy skin disease virus, Newcastle disease virus, Peste-des-petits ruminants virus, Porcine Teschovirus, Rabies virus and all other members of the Lyssavirus genus, Rinderpest virus, Sheeppox virus, Swine fever virus (Hog cholera virus), Teschen disease virus, Vesicular stomatitis virus.

Animal pathogenic mycoplasmas:

Mycoplasma mycoides subspecies *mycoides* SC (small colony), *Mycoplasma capricolum* subspecies *capripneumoniae* (strain F38).

Plant pathogenic viruses:

Potato Andean latent tymovirus, Potato spindle tuber viroid.

Plant pathogenic bacteria:

Clavibacter michiganensis subsp. *Sepedonicus* (*Corynebacterium michiganensis* subsp. *Sepedonicum* or *Corynebacterium Sepedonicum*), *Ralstonia solanacearum* Races 2 and 3 (*Pseudomonas solanacearum* Races 2 and 3 or *Burkholderia solanacearum* Races 2 and 3), *Xanthomonas albilineans*, *Xanthomonas axonopodis* pv. *citri* (*Xanthomonas campestris* pv. *citri* A), *Xanthomonas oryzae* pv. *Oryzae* (*Pseudomonas campestris* pv. *Oryzae*).



Plant pathogenic fungi:

Cochliobolus miyabeanus (*Helminthosporium oryzae*), *Colletotrichum coffeanum* var. *virulans* (*Colletotrichum kahawae*), *Magnaporthe grisea* (*pyricularia grisea/pyricularia oryzae*), *Microcyclus ulei* (syn. *Dothidella ulei*), *Puccinia graminis* ssp. *graminis* var. *graminis* / *Puccinia graminis* ssp. *graminis* var. *stakmanii* (*Puccinia graminis* [syn. *Puccinia graminis* f. sp. *tritici*]), *Puccinia striiformis* (syn. *Puccinia glumarum*), *Sclerophthora rayssiae* var. *zeae*, *Synchytrium endobioticum*, *Tilletia indica*, *Thecaphora solani*.

9.3 Legislation governing the use of SSBA in Australia - the National Health Security Act - Part 3

Part 3 of the [National Health Security Act 2007 and Regulations 2008](#) describes a national scheme for the regulation of SSBA in Australia and builds on Australia's obligations under the Biological and Toxin Weapons Convention (1975) and UN Security Council Resolution 1540 (2004).

The [Department of Health and Ageing](#) (DoHA) is the administrative body under the Act. Any institution that intends to store or perform research with, SSBA must be registered with DoHa before the agent is imported into their site.

From www.health.gov.au/SSBA:

“The deliberate release of harmful biological agents such as viruses, bacteria, fungi and toxins has the potential to cause significant damage to human health, the environment and the Australian economy.

In 2006, the Council of Australian Governments' (COAG) Report on the Regulation and Control of Biological Agents identified that the regulations in place at the time focused on safety rather than security; and that there was a need to regulate the secure storage, possession, use and transport of security sensitive biological agents to minimise the risk of use for terrorism or criminal purposes.

The aim of the SSBA Regulatory Scheme is to limit the opportunities for acts of bioterrorism or biocrime to occur using harmful biological agents and to provide a legislative framework for managing the security of SSBA. The scheme was developed using risk management principles to achieve a balance between counter-terrorism concerns and the interests of the regulated community and aims to maintain full access to SSBA for those with a legitimate need. The SSBA Regulatory Scheme also builds on Australia's obligations under the Biological and Toxins Weapons Convention and UN Security Council Resolution 1540.” (www.health.gov.au/SSBA – September 2015)

10 AUSTRALIAN NATIVE ANIMALS OR PLANTS

If you are planning to conduct research or teaching activities involving an Australian native animal or plant, or samples/parts from an Australian native animal or plant (*for example: fish, vertebrates, insects, invertebrates, fur, skulls, feathers, carcasses, bones, scats, algae, flowering plants, and non-flowering plants, seeds, flowers, leaves, branches, roots*) then you must take the points below into consideration.

Native animals and plants are protected under the Biodiversity Conservation Act (2016). Aquatic species may also be protected under the Fish Resources Management Act (1994).

- Please consider the requirements for [licence](#) to collect plants or animals.
- Please also consider the requirements for a [licence for fish and crustaceans](#).

For your Risk Assessment, the hazard is harm to native animal or plant populations. The control is seeking and gaining approval from the appropriate government department.



11 PLANTS THAT ARE POISONOUS, TOXIC, OR WEEDY

Poisonous/toxic plants must be handled to protect workers from the poison/toxin. Please contact your [Biosafety Partner](#) who will help you to assess the risks before you begin work.

For your Risk Assessment, the hazard is being poisoned by the plant. The risk assessment will identify the controls you will need to use.

If you are planning to conduct research or teaching activities involving a weedy plant listed on the Department of Agriculture and Food's Declared Plants List (*search for "Declared Plants List" on the DAFWA website <http://www.agric.wa.gov.au/>*) then you will need to handle it following the guidelines on the List. You must not release a pest plant into the environment.

For your Risk Assessment, the hazard is harming the natural or agricultural ecosystems by invasion of a weedy plant. The control is to fully contain the plant by following the guidelines on the Declared Plants List at all times.

12 INVERTEBRATES THAT ARE VENOMOUS, TOXIC, OR ABLE TO ACT AS VECTORS FOR DISEASE

If you are planning to conduct research or teaching activities involving biting/stinging or venomous/toxic invertebrates that could harm the handlers (*for example: bees, ants, jellyfish, coral*) then you must handle them using methods to protect workers from the bite/sting or venom/toxin.

Please contact your [Biosafety Partner](#) who will help you to assess the risks before you begin work.

For your Risk Assessment, the hazard is poisoning with invertebrate venom. The risk assessment will identify the control measures that you will need to take.

If you are planning to conduct research or teaching activities involving insects that are able to act as vectors for human, animal and plant disease (*for example: mosquitoes, ticks, thrips*) you must do the following. Consult Section 3 of the AS/NZS2243.3:2022 (the Australian/New Zealand Standard 2243.3:2022 can be accessed by searching the library databases <http://databases.library.curtin.edu.au/> for the Techstreet database and then for '2243.3') to identify the Risk Group (RG) that those insects should be handled at, and handle them using the appropriate Physical Containment (PC) level (Section 5 of the AS/NZS2243.3:2022). If you are able to handle the insects at the same PC level as their RG, then you do not need to seek approval from the Biosafety Partner to do this work. However, if you can't comply with these two sections of the Standard for any reason, or you are unsure, then you must contact your [Biosafety Partner](#) who will help you to assess the risks before you begin work.

For your Risk Assessment, the hazard is infection with disease spread by the vector. The first control is handling the sample under at least PC2 conditions or using methods approved by your Biosafety Partner. A second control may be vaccination.

13 TRANSPORTING BIOLOGICAL MATERIALS

Transporting biological materials is a regulated activity, and you must do it following the guidelines and regulations below, for transporting by walking, by vehicle (car, truck, bus, train), and by post or plane.



13.1 Guidelines for transporting biological materials by walking and carrying your samples.

You might need to transport biohazards (experiments or waste) by walking and carrying your samples between:

- two labs in the same building separated by non-lab corridors
- two labs in different buildings
- from a lab to a storage area.

You will need to package and label your samples to ensure that, no matter what happens to the package during transport, they will not:

- become contaminated by the environment
- escape containment to contaminate people or the environment.

You must double contain your microorganisms as described and shown below.

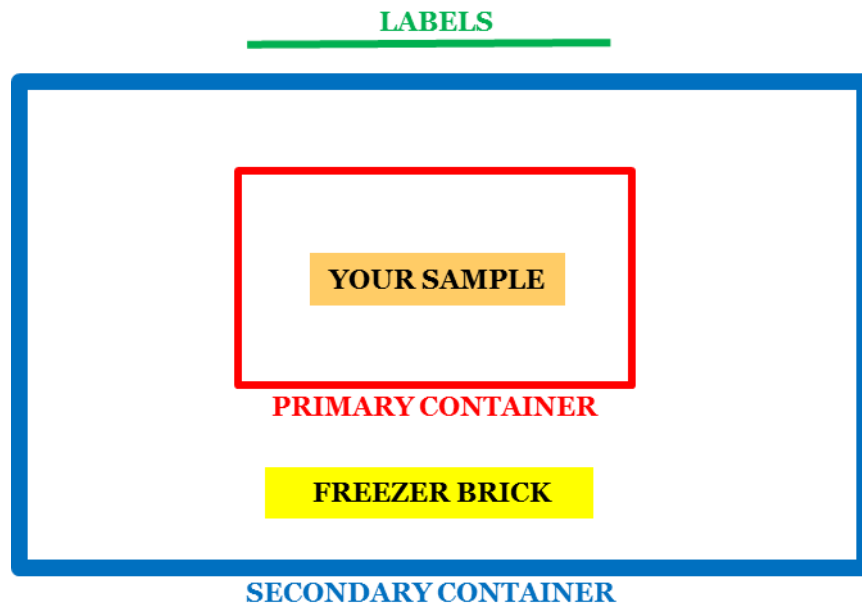

PRIMARY CONTAINER

- Must be sealed.
e.g. an eppendorf tube, a taped petri dish, a taped bag of waste.

SECONDARY CONTAINER

- Must be sealed.
- Must be rigid, solid, durable enough to survive being dropped.
e.g. a lidded plastic lunchbox, a taped polystyrene esky.



LABELS

- A biohazard symbol.
- A brief description of the contents (can be on a post-it notes).
- The name and contact phone number of a researcher not carrying the package, a Facility Manager, or the Biosafety Advisor.

REFRIGERANTS

- Use freezer bricks rather than wet ice.
- If you want to refrigerate your package using dry ice (carbon dioxide) or liquid nitrogen, then those are Dangerous Goods and have their own safe handling practices and regulatory requirements that are not covered here. Avoid using these refrigerants, but if you need to then you need to find out how to do so safely.

HIGHER CONTAINMENT CONSIDERATIONS

Biological materials such as genetically modified organisms (GMOs), quarantined materials, and live animals have their own transport requirements that also need to be fulfilled. If you want to use these materials, then please do the training specific for those materials.

13.2 Guidelines for transporting biological materials by vehicle (car, truck, bus or train), by post or by plane

You might need to transport biohazards (experiments or waste) by vehicle (car, truck, bus or train) by post or by plane.

You will need to package and label your samples to ensure that, no matter what happens to the package during transport, they will not:

- become contaminated by the environment
- escape containment to contaminate people or the environment.

Transporting biological materials by post or plane is a regulated activity, and you must do it following these regulations, which are summarised in these Guidelines:

- The IATA Dangerous Goods Regulations.
- The Australia Post, Dangerous and Prohibited Goods and Packaging Guide.
- The International Maritime Organization (IMO), International Maritime Dangerous Goods Code (IMDG Code).
- The Office of the Gene Technology Regulator (OGTR), Guidelines for the transport of GMOs.
- United Nations Recommendations on the Transport of Dangerous Goods. Model Regulations.

When transporting by post or by plane, the requirements for packaging and labelling are different depending on what biological materials you are transporting.

If you are transporting material that is infectious towards humans or animals, then it is classified as a Dangerous Good. Similarly, if you are transporting material that could contain microorganisms that could be infectious towards humans or animals (such as blood samples) then it is also classified as a Dangerous Good. See the section above for the different Categories of Dangerous Goods.

You need to be qualified in order to pack a Dangerous Good for transportation. World Courier runs training courses for packing Dangerous Goods. Or you can get the qualified staff of a courier company (such as World Courier) to pack your samples for you. The diagram below, from A/NZS2243.3:2010, shows the packing and labelling requirements.

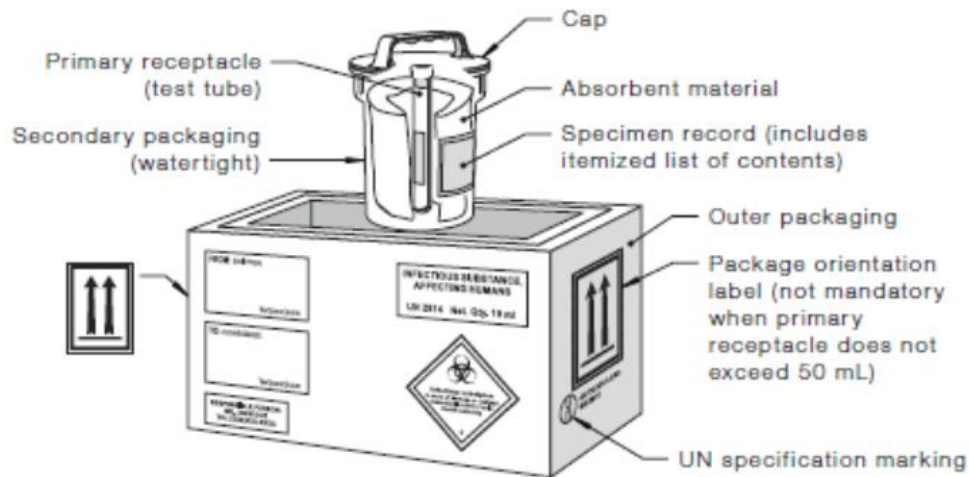

(a) Packing and labelling of Category A infectious substances

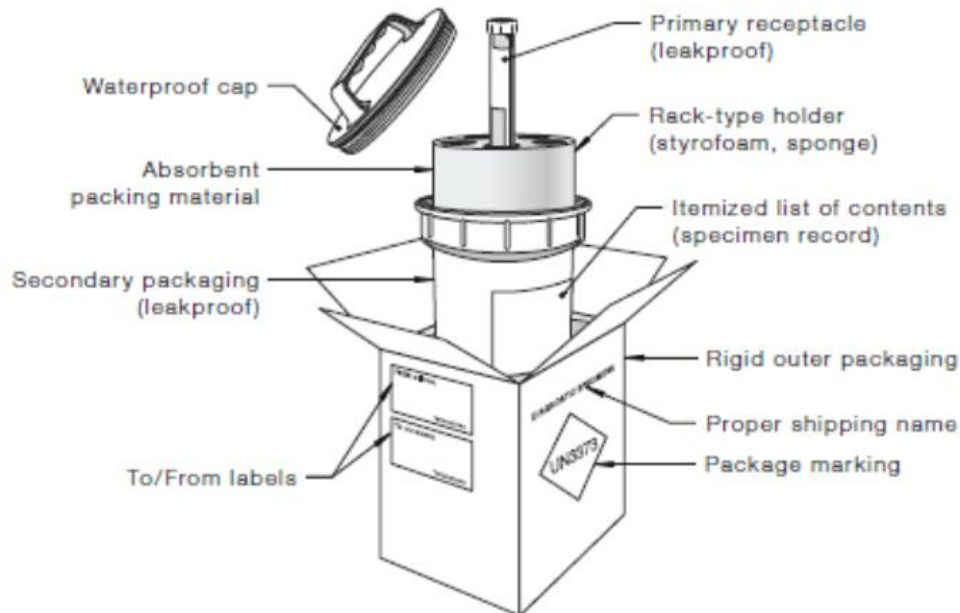

(b) Packing and labelling of Category B infectious substances

FIGURE 3 EXAMPLES OF TRIPLE PACKAGING SYSTEMS



MORE INFORMATION:

In Australia, Item 92.120 of the Civil Aviation Safety Regulations specifies required training for packing dangerous goods for transport by air. All persons who pack dangerous goods for transport by air (including enclosing the goods in packaging, marking or labelling the consignment or preparing a shipper's declaration) are required to successfully complete a course approved by the Civil Aviation Safety Authority, Australia.

The IATA Dangerous Goods Regulations define the requirements for certification, packing instructions, the maximum quantities that can be transported by cargo or passenger aircraft, the external labelling requirements (including the identifying UN number), and the details to be included in the attached Shippers Declaration for Dangerous Goods.

The Australia Post dangerous and prohibited goods and packaging guide is a source of useful information.

When transporting biological materials that do not contain microorganisms infectious to humans or animals, then you just need to double contain your samples to withstand the conditions of the journey.

These will include variations in temperature and air pressure, plus the physical rigours of being crushed under other items in the cargo hold of the plane. In the picture above, you can see features of packaging including multiple layers of sealed and rigid containers, padding and bunding between the layers, and labelling to identify the contents – all of these features will be needed for your packaging.

Australia Post or a courier company can help you to pack your materials to survive the journey. Always use packing materials designed for the purpose. Always fill in all the information that is asked for on the outer labels of the packaging – if you leave any of it blank than your package may seem suspicious and be stopped by the security systems of the post office or airport.

REFRIGERANTS

- Use freezer bricks rather than wet ice.
- If you want to refrigerate your package using dry ice (carbon dioxide) or liquid nitrogen, then those are Dangerous Goods and have their own safe handling practices and regulatory requirements that are not covered here. Avoid using these refrigerants, but if you need to then you need to find out how to do so safely.

HIGHER CONTAINMENT CONSIDERATIONS

Biological materials such as genetically modified organisms (GMOs), quarantined materials, and live animals have their own transport requirements that also need to be fulfilled. If you want to use these materials, then please do the training specific for those materials.

OTHER CONSIDERATIONS

- Before you send a biological sample, you must advise the recipient to expect it.
- If you ask someone to send you a biological sample, then it is your responsibility to tell the sender to pack the sample following the regulations in this Guideline.
- Biological samples entering Australia will be subject to quarantine – you can find out information about quarantine in this manual.
- Unpack packages carefully, and in a biosafety cabinet if necessary in case the containers have broken during transport.



Links to documents that regulate the transportation of biological materials.

- [The IATA Dangerous Goods Regulations](http://www.iata.org/publications/dgr/Pages/index.aspx) (<http://www.iata.org/publications/dgr/Pages/index.aspx>)
- [The Australia Post, Dangerous and Prohibited Goods and Packaging Guide](#)
- [Australian Code for the Transport of Dangerous Goods by Road and Rail](#)
- [The International Maritime Organization \(IMO\), International Maritime Dangerous Goods Code \(IMDG Code\)](#)
- [The Office of the Gene Technology Regulator \(OGTR\), Guidelines for the transport, storage and disposal of GMOs](#)
- Packaging for surface transport of biological material that may cause disease in humans, animals and plants (AS 4834) ([all Australian Standards are accessible through the library](#))
- [United Nations Recommendations on the Transport of Dangerous Goods. Model Regulations](#)

14 BIOLOGICAL CONTAINMENT FACILITIES

Curtin University has several biological containment facilities that are used to contain its biohazardous microbiological/plant/animal research and teaching activities.

Curtin has a number of research facilities that are [Certified](#) by the [Office of the Gene Technology Regulator \(OGTR\)](#), in which teaching and research with genetically modified organisms can be undertaken. There are PC1-level, PC2-level and PC3-level laboratory, plant, and animal facilities available.

Curtin has a number of research facilities that are [Approved Arrangements](#) by the [Department of Agriculture](#), in which teaching and research with quarantined biosecurity materials can be undertaken. There are QC1-level, QC2-level and QC3-level lab, plant, and animal facilities available.

If you would like to access any of these facilities, please contact your [Biosafety Partner](#), who will direct you to contact the Facility Manager in charge of an appropriate facility. Alternatively, you can apply to have your current facility Certified or Approved, by contacting your [Biosafety Partner](#).